

SPECTRA S2

User Manual



speCtra[®]
AUSTRALIA & NEW ZEALAND

WELCOME TO YOUR SPECTRA S2 BREAST PUMP

Congratulations on becoming the owner of a Spectra S2 hospital grade double electric breast pump. Your Spectra S2 is designed to make life easier for you, with a host of features to ensure effective expressing. If you have any questions about using your Spectra S2, please check out our website for more information or get in touch with our customer service team at any time.

Features

- **Double-Sided Pumping:** Your Spectra S2 comes with everything you need for double pumping. Expressing from both breasts at once saves you time and better supports milk supply.
- **Letdown Mode:** Switch with a touch to letdown mode, which is a light, quick fluttering mode designed to speed the start of milkflow - just the way your baby does.
- **Fully Adjustable Cycle & Vacuum Settings:** Touch button controls allow you to easily adjust the cycle and vacuum levels until you find what works best for your body.
- **Night Light:** Choose from two different light levels on the Spectra S2's integrated night light, a feature you will love when pumping at night.
- **Stylish, Portable Design:** Spectra has endeavoured to make the most portable and convenient hospital grade pump ever, with an integrated handle and bottle stand to make life a little easier.

General Safety Guidelines

- Close supervision is necessary when used near children.
- Use the product only for its intended use and with attachments recommended by the manufacturer.
- Handle the power cord, adaptor and plug with care; do not leave on a heated surface, do not pull or twist the cord, and do not wrap the cord around the adaptor body.
- Do not use near water.
- Do not use in the presence of concentrated oxygen or pressurised gases.
- Unplug and store out of reach of children when not in use.



IMPORTANT SAFEGUARDS

Carefully read the instructions prior to using the Spectra S2. Follow the safety guidelines above when using your pump. Failure to follow these guidelines could result in damage to the pump and/or injury to yourself and those around you.

INCLUDED WITH YOUR SPECTRA S2

Your Spectra S2 comes with everything you need to double pump, including two sets of tubing, backflow protectors, breastshields, duck valves, and bottle kits.



PUMP MOTOR



POWER ADAPTOR

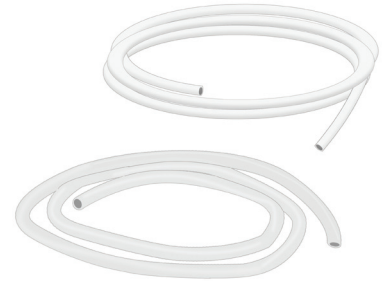

TUBING (x 2)



BACKFLOW PROTECTOR (x 2)



BREASTSHIELD (x 2)



VALVE (x 2)

BOTTLE (X 2)

BOTTLE NECK (x 2)

TEAT (x 2)

BOTTLE CAP (x 2)



- Sterilise all parts prior to first use except for tubing, pump motor, and power adaptor.
- Do not get the pump motor or tubing wet. Washing or sterilising the tubing can cause milk or moisture to enter the pump motor, leading to mould or bacteria growth. Once milk or moisture enters the tubing it can no longer be assured as hygienic and the tubing should be replaced.
- Sterilise bottles before use. Inspect teat before each feeding and discard if torn.
- Our milk collection bottles are freezer safe.

QUICK START GUIDE



1. Sterilise Parts

Sterilise all parts **except for tubing and pump motor** using any preferred sterilisation method. To sterilise by boiling disassemble all parts and cover with water in a large stock pot. Bring to a boil for 5 minutes. Use tongs to remove parts from pot and set to air dry on a clean paper towel.



2. Assemble

Firmly press valve into the bottom of the breastshield, then twist breastshield onto collection bottle. Press backflow protector into breastshield, and place tubing firmly onto backflow protector and onto air ports on pump motor.



3. Fit to Breast

Place breastshield so nipple is centred within the flange. While pumping your nipple should move freely within the flange with 2-3mm space, not rubbing on the sides and without excess areola being drawn in. You should not feel any pain. See our website for more on breastshield sizing.



4. Understanding Settings

You should plan on trying out different settings to find what works best for you. To start, begin in massage mode. Increase vacuum strength to trigger milkflow. Switch to expression mode. Try adjusting vacuum and cycle speed. Pumping shouldn't be painful - never use settings out of comfort level.

Pumping Tips

Relax and stay hydrated. Set yourself up with a glass of water, snacks and try to minimise interruptions for the next 15-30 minutes.

Remember who you are pumping for. Try pumping with a picture or video of your baby, or a piece of your baby's clothing, to encourage milkflow.

Massage your breasts to encourage milkflow. Before and during pumping, massage your milk ducts by pressing in small gentle circles starting at the top of the breast and working down.

Free a hand. With practice, you may be able to use the crook of your elbow to support one collection bottle while holding the other, or invest in a hands free pumping bra.

ASSEMBLING YOUR MILK COLLECTION KIT

Before assembling, make sure you've sterilised and washed your milk collection kit (**except** for the tubing). Make sure all parts have been able to completely air dry prior to assembling.

Start by inserting the valve firmly into the breastshield. Then, screw the breastshield onto the milk collection bottle. Assemble the backflow protector as shown below, and then firmly insert it into the breastshield.

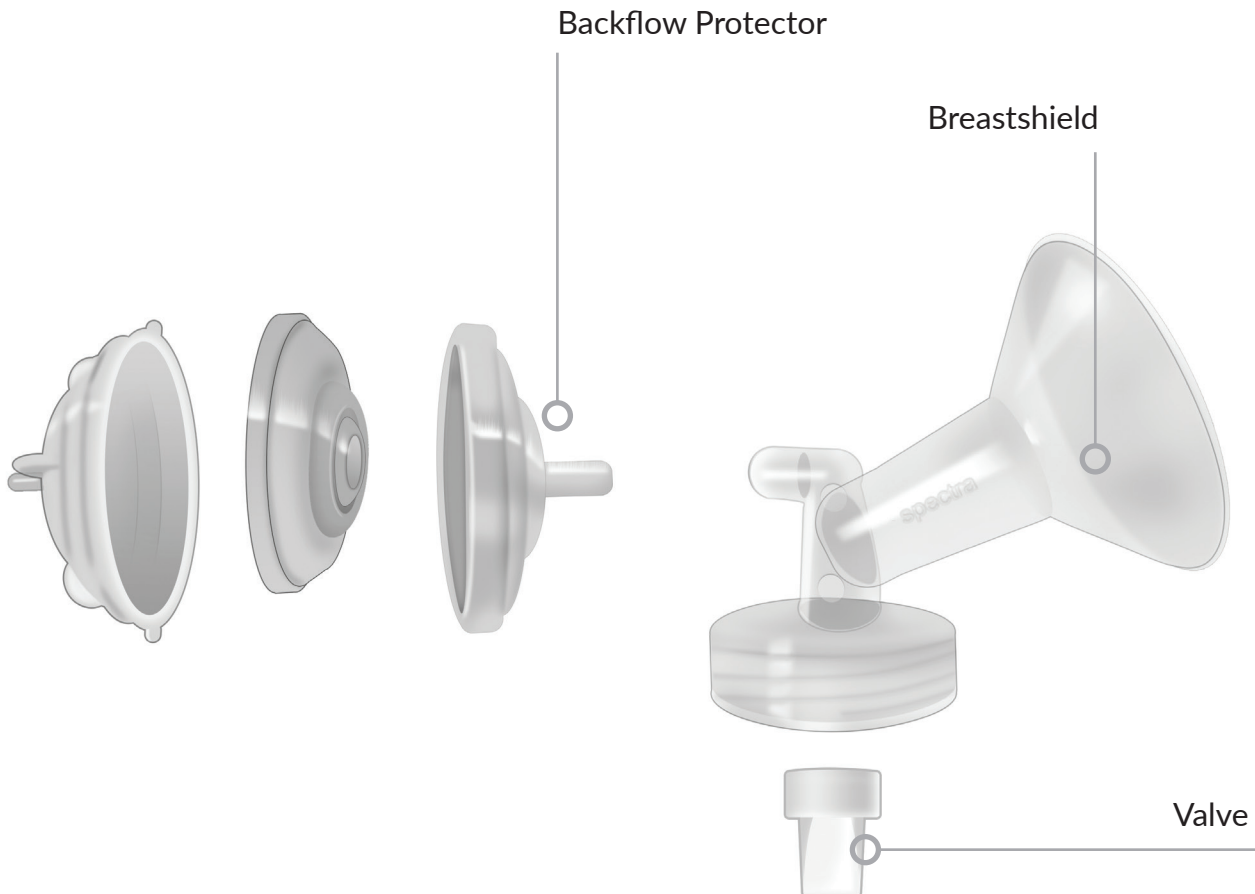

Note: Spectra Valves

Your Spectra breast pump will have shipped with either white silicone duck valves, as shown above, or the blue valve head & membrane as shown below. Both valve styles are interchangeable, and available to purchase on our website.

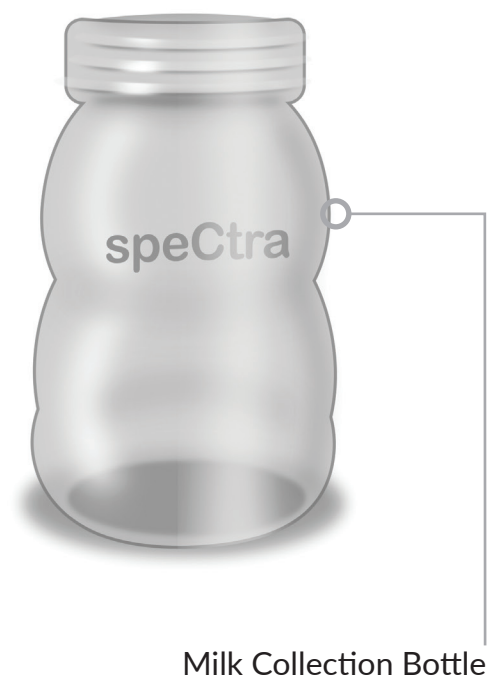

ASSEMBLING YOUR SPECTRA S2

HOW TO ASSEMBLE YOUR BREAST PUMP FOR USE



1. Attach Tubing

Assemble the milk collection kit as shown on the previous page. Make sure all parts are completely dry prior to assembly. Attach tubing firmly onto the backflow protector.



2. Double Pumping

Insert tubing firmly over each air port. Make sure tubing is firmly placed on backflow protector of both collection kits.

Tip: If you're having trouble removing the cap over the second air port, try using a pair of tweezers and gently rocking it back and forth.



3. Single Pumping

Insert tubing firmly over one air port. Make sure cap is firmly and completely covering the second air port.

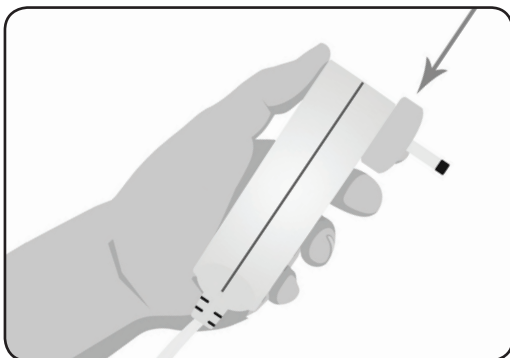

4. Insert Power Adaptor

Assemble power adaptor by sliding the prong firmly into place. You should feel and hear a loud click.

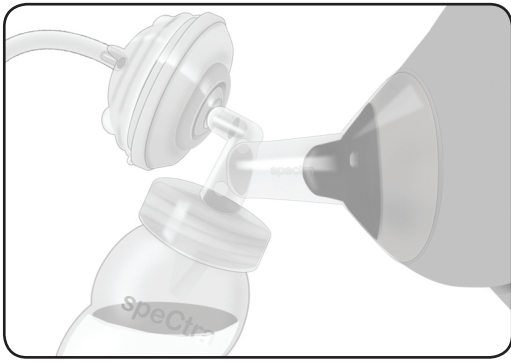

Insert the power adaptor into the pump motor, and then plug it into mains. Press the power button to power on your pump.

PUMPING INSTRUCTIONS









To begin pumping, place the breastshield over the nipple. Use one hand to hold the breast and the other to hold the breastshield as you adjust your breast into the nipple so the nipple is centred in the flange and an airtight seal is formed around your breast or areola. Repeat for double pumping.

Tip: Use the inside of your elbow to hold the first breastshield in place while you adjust the second.

- Press the  button. The screen will light up and the pump will initiate.
- Press the  button to enter Massage Mode. A wavy lines icon matching the button will appear on the upper-left corner of the display screen.
- When your milk starts flowing, press the  button again to enter Expression Mode. The wavy lines icon will disappear from the display screen.
- Adjust the vacuum to comfort level. Start off with the vacuum on low, and then gradually increase the vacuum setting to your comfort level. Never set the vacuum level higher than your comfort level.
- Express milk for 10-15 minutes per breast. To maintain supply for an exclusively breastfed baby, we recommend pumping every 2-3 hours, or 7-8 times per day for long enough to completely drain the breast; then, an additional 5 minutes to signal the demand for the body to make more milk.
- When you wish to stop expressing, press the power button then remove the milk collection kits from your breasts. Do not attempt to remove the collection kits without first breaking suction. Turning off the pump will break suction.

CONTROLS

Massage Mode		A fast cycle speed (70 CPM) that mimics the fast, fluttering suckling that baby does to stimulate letdown.
Expression Mode		A slower cycle speed (5 steps between 38 and 54 CPM) that mimics the slow, steady suck-and-swallow that baby does once milkflow is established.
Cycle Speed	 CYCLE	The amount of suck-and-release cycles per minute (CPM). Adjustable between 38 and 54 CPM in Expression Mode, and locked at 70 CPM in Massage Mode.
Vacuum Strength	 VACUUM	The strength of the suction. Adjustable between 1 and 5 in Massage Mode and 1 and 12 in Expression Mode; 1 being low and 12 high.
Night Light		Illuminates at high and low intensities. Press the light button 1 time for high; 2 times for low; 3 times to turn off.
Timer	 	Timer starts as soon as the pump is powered on. The pump will automatically power off after 30 minutes. Resets each power cycle.

BREASTSHIELD SIZING GUIDE

The Spectra S2 comes with size 24mm breastshields. This is the most commonly fitted shield size; however, many women will fit better in other sizes. A properly sized breastshield is important to ensure the best performance of your pump. An improperly fitted breastshield can hinder milk output, cause discomfort, and in extreme cases cause injury. To determine the shield size you need, pump for 5 minutes using the provided shields. Your nipples will expand while milk is being expressed so it's important to measure after they have swollen to ensure the size you select will provide enough room. After you pump, measure the diameter of the nipples at the base as illustrated in the image to the right. Repeat the process a few times to make sure you have the right measurement. Select a shield size that is 2-3mm larger than this measurement.

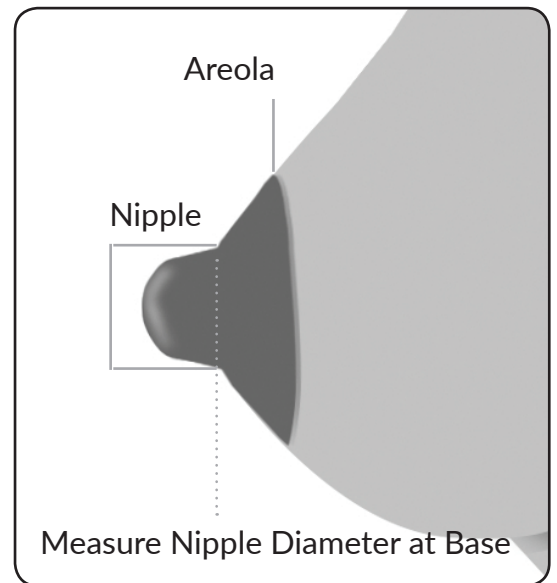

Signs your breastshield may be too small

- Painful rubbing of nipple in flange.
- Nipple not moving freely inside of flange.
- Redness of the nipple.
- Whiteness of the nipple and/or a white ring around the base of the nipple.
- Little milk is being expressed.
- General discomfort while pumping.

Signs your breastshield may be too large

- Excess areola is drawn into the flange (a small amount of areola may enter the flange for some women; however, it should never be uncomfortable or painful).
- Sensation of pulling and/or pulling pain.
- Nipple is pulled to the end of the flange.
- Shield falls from the breast while pumping or milk pools between shield and breast.
- Little milk is being expressed.
- General discomfort while pumping.

MORE INFORMATION ABOUT SHIELD SIZING

- You should check your shield size every so often throughout your pumping journey, especially if you are noticing a decrease in milk output.
- We suggest taking measurements of the swollen nipple after pumping (rather than the unswollen nipple before pumping) because every woman's nipples will respond differently to pumping.
- Your measurements might be different throughout the day. For example, you might be fuller in the morning after going a few hours without pumping and/or feeding at night, warranting a larger size. You might also be smaller in the evening after consistent pumping or feeding throughout the day.
- You might be larger at the beginning of a pumping session, and smaller after some milk has been expressed.
- Your measurements might change after your milk supply is well-established (about 10 weeks postpartum).
- One breast may perform better with a different sized breastshield than the other.

CLEANING & STERILISATION

STERILISE BEFORE FIRST USE



What to Sterilise

Sterilise all parts before first use except tubing, pump motor, and power adaptor. Sterilise all parts that might come in contact with your breastmilk, including bottles, breastshields, valves, backflow protectors, bottle necks, sealing discs, caps, and teats.



Boiling Water Method

Select a large stock pot large enough for all of your pump parts to fit without pressing against each other. Place parts into pot, making sure they are completely disassembled. Fill the pot with more than enough water to cover all of your pump parts. Make sure there are no air pocket and that parts are not nestled together (check that bottles don't have any air pockets or smaller parts like valves in them).

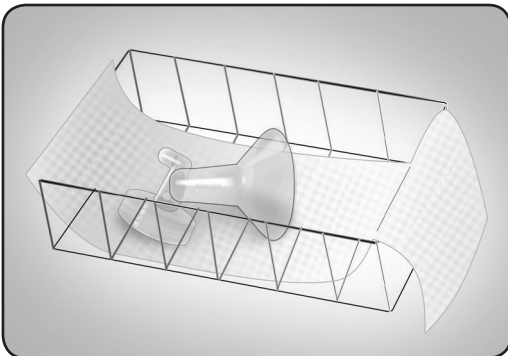

Place the pot on the stovetop and turn on the heat. Heat until a rolling boil: boil for 5 minutes. Do not let the water run dry as this will melt your parts.

After 5 minutes, remove from heat. Use a pair of tongs to carefully remove each part and set on a clean paper towel. Allow to completely air dry prior to assembling.

Steam Sterilisers / Other Methods

If you're using a microwave steam steriliser, a chemical solution, or another sterilisation method please follow the manufacturer's instructions. We don't normally recommend chemical solutions unless you don't have access potable water.

Precautions

- Do not get the tubing wet. Moisture can cause irreparable damage to the motor and invite mould and bacteria to grow inside of your pump.
 - Do not overcrowd when using the boiling water method because this can cause parts to permanently warp. Repeat the process multiple times in a smaller pot if you don't have a large enough pot.
 - Sterilisation can cause discoloration of the plastic. This is normal and safe for use.
 - Over-sterilisation can cause parts to wear down more quickly than they should. Following a good cleaning method (see next page) means you don't need sterilise more than just once.
- 9 • If your care provider has given you alternative cleaning & sterilisation instructions, always adhere to those.

CLEANING & STERILISATION

CLEAN YOUR PARTS DAILY

What Needs to be Cleaned



Clean all parts that come in contact with breastmilk after using them. You don't have to clean your parts after each use (unless your care provider has advised you to), but make sure you keep your pump parts in a sealed container in the refrigerator between uses. **Do not wash the tubing.**

Note: you do not need to clean your backflow protectors unless you see milk or moisture in them.

Hand Washing Parts



To hand wash parts you'll need access to potable water, regular dish soap, a dedicated wash basin & sponge or bottle brush for your pump parts, and paper towels. Add your pump parts to your wash basin and fill with warm soapy water. Make sure they are fully disassembled (check that valves are removed from breastshields and so on). Wash the surfaces, interior and crevices of each part, and be especially careful with the valve. Rinse thoroughly under a stream of cool, clean water, and set to air dry on a clean paper towel. Allow parts to completely air dry prior to assembly.

Washing in the Dishwasher

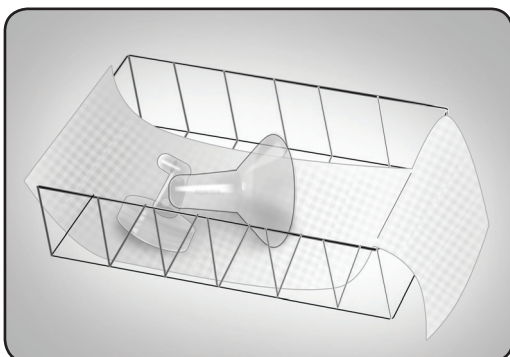

You can wash your breast pump parts in the top rack of the dishwasher on a normal dish washing setting. A dishwashing basket with a closing lid is great for preventing small parts from getting lost. Make sure that your dishwasher is set to air dry, **not to heat dry**, as that can cause your parts to warp. Try to handwash the valves and membranes whenever possible as these are delicate and easily lost.

Allow parts to completely dry in dishwasher or remove and air dry on a clean paper towel, prior to assembling.

Other Cleaning Methods

If you're following another cleaning method, such as a cleaning wipes, always follow the manufacturer's instructions. We recommend hand washing or washing in the dishwasher whenever possible.

TIPS FOR EXPRESSING BREASTMILK

- **Relax and Stay Hydrated:** Set yourself up with a glass of water and snacks, and minimise interruptions for the next 15-30 minutes as much as possible.
- **Set the Stage:** Have a regular pumping location. Choose a seat that is comfortable and provides back support so you can relax while still sitting up straight. Keeping a small towel nearby will help you clean as needed.
- **Routine and Ritual:** You can condition your body to express easily by pumping with the same setup each time. For example, try always using the bathroom first, then fix your favorite drink, grab your clean milk collection kits, sit down in your regular spot, have your drink, and then start pumping. Try always expressing after brushing your teeth, or playing the same game on your phone while you express. Your body will start to recognise what's going on.
- **Visualise Success!** Just as ritual can help contribute to effective pumping, some creative visualisation can also help. Think of a gushing faucet, a flowing river, or simply visualise your milk coming out.
- **Remember Who You are Pumping For:** Some women find a picture of their baby, a baby item or item of clothing that smells like their baby can help trigger letdown. Some find that a recording of their baby's cry is a powerful letdown trigger.
- **Massage to Start:** Stimulate your breasts before pumping can ease letdown. Rub in small circles all around the breast (don't forget in the armpit area) on both sides before you turn your pump on.
- **Massage to Continue:** When you notice your milkflow starting to slow, massaging your breast while focussing on any areas that seem to still contain milk can sometimes restart milkflow or encourage another letdown.
- **Pump more Often:** Increasing the frequency of your pumping sessions rather than the amount of time you pump is generally more effective at increasing the volume you can express.
- **Pump on Schedule:** Pumping at the same time each day can help teach your breasts to be ready to let the milk flow. Some women find pumping in the morning brings about the biggest 'payoff' while other pump after their baby's bedtime, a much more relaxed time of day.
- **Free a Hand:** With practice, you may be able to use a cushion or the crook of your arm to support one milk collection kit while you hold the other. This gives you a free hand to turn pages, scroll down screens, or use the remote. If you are serious about getting things done while pumping, a hands-free pumping bra will free up both your hands.
- **Pain should not be "Pushed Through":** If you are experiencing discomfort or pain while pumping, turn the suction down, try a little bit of lubricant such as coconut oil on the shield, and contact your care provider or Spectra Customer Support ASAP if the pain continues.

Note: When you express and how often will depend on your specific situation. We have provided some basic instructions here, but you may wish to ask your care provider for additional help. More information is also provided on our website and through customer support. Contact us if you need assistance.

BREASTMILK STORAGE

Freshly Expressed Breastmilk

At room temperature (up to 26°C / 78°F)	4 - 8 hours
--	-------------

In the cooler bag with an ice pack (up to 15°C / 59°F)	12 - 24 hours
---	---------------

In the back of the refrigerator (up to 4°C / 78°F)	3 - 8 days
---	------------

Frozen Breastmilk Prior to Feeding

At room temperature (up to 26°C / 78°F)	<i>Should never be thawed at room temperature! Always thaw in the refrigerator.</i>
--	---

In the cooler bag with an ice pack (up to 15°C / 59°F)	Until thawed.
---	---------------

In the back of the refrigerator (up to 4°C / 78°F)	24 - 48 hours
---	---------------

Fresh Breastmilk after Feeding

At room temperature (up to 26°C / 78°F)	1 - 2 hours
--	-------------

In the cooler bag with an ice pack (up to 15°C / 59°F)	Up to 4 hours
---	---------------

In the back of the refrigerator (up to 4°C / 78°F)	Up to 24 hours
---	----------------

In the freezer (-18-20°C / -4-0°F)	<i>You should never freeze breastmilk after feeding.</i>
---------------------------------------	--

Note: These guidelines are based on current international recommendations for a healthy, full-term baby. You should always adhere to your care provider's advice.

BREASTMILK STORAGE (CONTINUED)

Previously Refrigerated or Frozen Breastmilk after Feeding

At room temperature (up to 26°C / 78°F)	1 hour
In the cooler bag with an ice pack (up to 15°C / 59°F)	1 - 2 hours
In the back of the refrigerator (up to 4°C / 78°F)	1 - 2 hours
In the freezer (-18-20°C / -4-0°F)	<i>You should never refreeze breastmilk.</i>

In the Freezer

In the Freezer Compartment of a Refrigerator (-15°C / 5°F)	1 - 2 weeks
Conventional freezer (-18-20°C / -4-0°F)	3 - 6 months
Deep Freeze (-20°C / -4°F or lower)	Up to 1 year

Tip: Check your freezer often to make sure it's working. Should the power go out, try not to open your freezer to keep the contents, including your frozen breastmilk, cool and insulated as long as possible. Breastmilk is still considered frozen when there is any amount of ice remaining in it.

Note: These guidelines are based on current international recommendations for a healthy, full-term baby. You should always adhere to your care provider's advice.

TROUBLESHOOTING

Pump Will Not Turn On

Possible Problem	Possible Solution
Plugged in, no power	<ul style="list-style-type: none">• Check that the adaptor is plugged into mains and into the pump.• Check that the adaptor is assembled properly.• Check that the mains outlet is working properly.
Loose rattling sound inside	<ul style="list-style-type: none">• Contact customer support.

No / Low Suction

Vacuum settings have accidentally been changed	<ul style="list-style-type: none">• Try increasing vacuum intensity settings.
Backflow protector membrane making squishy sound	<ul style="list-style-type: none">• Are valves attached to the breastshield?• Are you replacing valves regularly?
On just one side	<ul style="list-style-type: none">• Is valve seated correctly on breastshield?• Check the valve for tears & replace valve.• Check that tubing is snugly attached.
Backflow protector	<ul style="list-style-type: none">• Check for correct assembly.• Make sure completely dry prior to assembly.• Replace backflow protector regularly.• Always use backflow protectors when pumping.
Tubing	<ul style="list-style-type: none">• Check for snug attachment on air ports and backflow protectors.• Check for damage.
While Single Pumping	<ul style="list-style-type: none">• Make sure cap is fully covering unused air port on pump.
Air is leaking between breastshield and breast	<ul style="list-style-type: none">• Make sure breast is inserted correctly into breastshield so that vacuum is maintained constantly as pump sucks and releases.• Check breastshield sizing (pg. 8).
Internal tubing has come loose	<ul style="list-style-type: none">• Place finger directly over air ports and turn on the pump. If you do not feel suction, contact customer support.

CARING FOR YOUR SPECTRA S2

Replacing Parts

To properly maintain your Spectra S2, you'll need to replace parts on a regular basis. Not replacing parts will make your pump work harder, leading to unnecessary wear and tear on the motor.

- Valve Membrane: Replace every 2 - 8 weeks, or when you notice a decrease in suction.
- Duck Valve: Replace every 2 - 3 months, or when you notice a decrease in suction.
- Backflow Protector: Replace every 3 - 6 months.
- Breastshield: Replace every 6 months.
- Tubing: Replace should moisture ever enter the tubing.

Warranty & Repair

This product is warranted by the supplier to be free from defects in material and workmanship for a period of 2 years from the date of purchase. This warranty does not cover damage caused by accident, misuse, abuse, improper maintenance, unauthorised modification, or connection to an improper power supply. For warranty claims, service, and repair please contact customer support.

Spectra Baby services and repairs pumps outside of warranty coverage. For more information on services provided, cost, or to book a service, visit our website.

Disposal

- Spectra Baby encourages used pumps in working order to be donated.
- Milk collection kits, bottles, and other breast pump accessories are for single-person use only and are unhygienic to be used by more than one person. They should not be reused second-hand.
- Breastshields, bottles, backflow protector casings, and other hard plastic parts can normally be recycled; check with your local authority.
- Silicone parts including duck valves, membranes, backflow membranes, tubing, and teats cannot be recycled and must be thrown away.
- The Spectra S2 breast pump & adaptor must not be disposed of with your regular household waste. It must be taken to a designated electronics recycling location. For more information about where you can dispose of electronic waste, please contact your local authority. This is to comply with EU Directive 2002/96/EC on Wasted Electrical and Electronic Equipment (WEEE).

TECHNICAL SPECIFICATIONS

Vacuum Strength	320mmHg
Grade	Hospital Grade
Massage / Letdown Mode	Yes
Cycle Speed (Expression Mode)	5 Steps between 38 and 54 Cycles per Minute (CPM) 38 42 46 50 54
Cycle Speed (Massage Mode)	70 Cycles per Minute
Power	Mains
Double Pumping	Yes
Weight	0.99kg
Warranty	2 Years
Motor Life	1500 Hours
Country of Origin	South Korea
Certifications	CE, FDA, ISO13485, ISO9001
Electromagnetic Compatibility	Compliant with IEC 60601-1-2:2007 Portable communications devices (i.e. mobile phones & 2-way radios) can impact the functionality of the Spectra S2. Should you experience interference, we recommend moving the Spectra S2 at least 1 metre away from these devices while in use.

Environmental Conditions

Operating Temperature	5°C - 40°C
Operating Humidity	15% - 93% non-condensing
Storage Temperature	-20°C - 60°C
Storage Humidity	15% - 93% non-condensing



© 2018 Chabalala Pte Ltd
Tel: +61 (07) 3053 8669
support@spectra-baby.com.au
spectra-baby.com.au